



Consolidated™ Condensed Catalog

Pressure Relief Solutions

- Safety Relief Valves
- Safety Valves

Consolidated

a Baker Hughes business

Table of Contents

Baker Hughes is looking to the future	4-5
Consolidated Safety Relief Valves	6
1900-DM Series Safety Relief Valve	7
1900 Series Safety Relief Valve	8
19000 Series Safety Relief Valve	9
1982 Series Safety Relief Valve	10
2478 Series Relief Valve.....	10
Consolidated Pilot-Operated Safety Relief Valves.....	11
2900 Gen II Series Pilot-Operated Safety Relief Valve.....	12
3900 Series Pilot-Operated Safety Relief Valve	12
4900 Series Pilot-Operated Safety Relief Valve	13
13900 Series Pilot-Operated Safety Relief Valve.....	13
Consolidated Safety Valves	14
1700 Series Maxiflow™ Safety Valve	15
2700 Series Safety Valve	15
1811 Series Safety Valve	16
1511 Series Safety Valve	16
1541-3, 1543-3 Series Safety Valve	17
1900/P Series Safety Valve	17
2900-40 Series Pilot-Operated Safety Valve.....	18
Consolidated Electromatic Ball Valve System	18
3500-5 Series EBV Electromatic™ Ball Valve System.....	18





Baker Hughes is looking to the future

The world is rapidly changing. In the dynamic environment of Energy Transition, it's more important than ever to innovate and provide solutions that help our customers face new challenges with confidence in their process applications.



Optimize Service



Improve Reliability



Increase Efficiency



Reduce Emissions

Any process that moves or stores fluid requires a valve. You need to be assured that when designing systems for production, transportation or storage of process medias, you've got the best and safest in pressure relief.

Optimize Service

Our digital suite of Valve Lifecycle Management tools coupled with our global network of Consolidated™ Green Tag™ Centers help you easily identify and service the valves that need it the most, making turnarounds and planned maintenance easier.

Improve Reliability

Our engineers work closely with our customers and regulatory agencies to ensure that our valves are designed for compliance and each specific installation, maintaining safe and reliable performance over the installed lifecycle with reduced maintenance.

Increase Efficiency

Our legacy of innovating control valve and pressure relief valve technology provides the right solutions to ensure installed valves are configured and sized to reduce operational costs, maximize process efficiency and keep critical processes running smoothly.

Reduce Emissions

Fugitive emissions not only cost money but can be harmful to the environment. With an ever-growing number of companies committed to achieving carbon neutral status in the next decade, best-in-class leak tightness and superior valve technology are required in every process design.



Consolidated Safety Relief Valves

In compliance with:

- ASME Section VIII Process Application Standards
- ASME Section I Boiler Application Standards
- Many other Global and Regional Standards

Safety relief valves often serve as the point-of-protection against potentially dangerous circumstances, so it is important that they be dependable. Consolidated safety relief valves have maintained a reputation for excellence and reliability for more than a century.

The Consolidated product line has demonstrated a number of innovative solutions, too. Safety relief valve innovations from the product line include the *Cryodisc™* and *Thermodisc* temperature compensating discs, Dual Media, True Zero-Leakage Pilot, and the 2900 Generation II pilot-operated valve with Full Nozzle Integral Sensing.

A full range of valves

Baker Hughes™ provides a full range of Consolidated safety relief valve styles, sizes, options and configurations tailored for multiple industries, applications, environments, and media. From spring-actuated to pilot-operated, each pressure relief valve is configured to offer safe and efficient process flow control in challenging overpressure applications.

Meeting evolving needs

Baker Hughes continues to pursue quality and pro-active approach through regular collaboration with our customers and by staying actively involved in the development of regulatory compliance standards. We configure, engineer, and manufacture safety relief valves that adhere to industry regulations and global and regional standards while helping meet our customers' evolving needs.

Applications:

- Chemical and petrochemical
- Refinery
- Power generation
- Economizer (Water)
- Liquid Phase Thermal Fluid Heaters
- Hydrogen Systems
- MSR – Moisture Steam Re-heater
- Turbine gland steam seal
- Pegging steam/auxiliary steam
- De-aerators
- Feed-water heaters – tube side and shell side
- Pumps – recirculation line protection
- Fuel oil pumps
- Ammonia systems
- Scrubber systems
- Air compressor
- Miscellaneous pumps



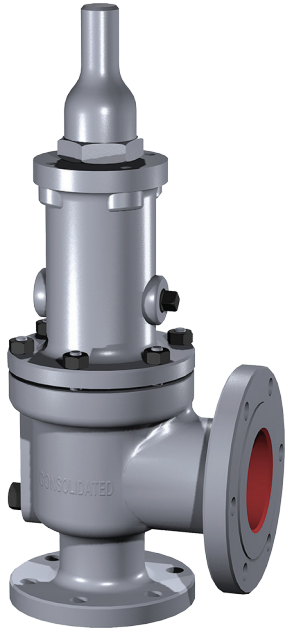

1900-DM Series Safety Relief Valve

Inlet Sizes:	1" through 12"
Inlet Ratings:	ASME Class 150 through 2500 EN 1092-1 PN 10 through PN 400
Outlet Sizes:	2" through 16"
Outlet Ratings:	ASME Class 150 and 300 EN 1092-1 PN 10 through PN 40
Orifice Sizes:	D through W
Set Pressure Range:	4 to 10000 psig (0.27 to 689.5 barg)
Temperature Range:	-450°F to 1500°F (-268°C to 815°C)
Materials:	Cast carbon steel body with stainless steel trim
	ASME B&PVC Section XIII (UV Designator) & Code Case 2787
	PED
Certifications:	China Manufacturing License (CML)
	API 520, 521 and 526
	NACE
	Others available upon request

The 1900 DM trim is ideal for any liquid or gas application, two-phase liquid and gas, flashing or multiple relief case scenarios.

The patented innovation of the Dual Media trim made it the first spring-loaded safety relief valve in the industry to be "dual certified", as defined by API Standard 520 Part 1, 10th Edition – Sizing and Selection. Dual Certified is defined as pressure relief valves that are both vapor/gas flow certified, and liquid flow certified where dual certification is achieved without making any modifications or adjustments to the relief device when switching fluids during the flow testing.

Options for 1900-DM Series Safety Relief Valve

1900-DM-CD

The patented Cryodisc (CD) technology is the ideal solution for cryogenic applications; offering premium seat performance before and after a relief event.

Low temperature media creates thermal stresses in the material that deflect the patented disc thermolip downward creating uniform contact pressure on the nozzle seat resulting in enhanced seat tightness. The Cryodisc option is also available for the 1900 liquid (LA) and gas (GS) trims, and the 2900 Gen II.

1948/49-DM High Pressure

The 1900 DM API 10/15K (48/49) High Pressure design combines the technology of the Dual Certified 1900 Dual Media with a forged Block Body design to handle high pressure offshore production (FPSO, FLNG, etc.) compression & auxiliary system applications. The Consolidated block body design is available for set pressures up to 10000 psig (689.5 barg).

Consolidated Safety Relief Valves

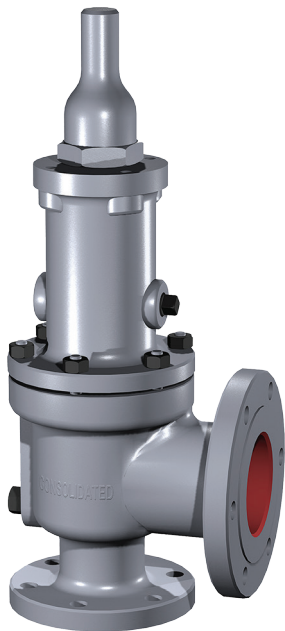

1900 Series Safety Relief Valve

Inlet Sizes: 1" through 12"

Inlet Ratings: ASME Class 150 through 2500
EN 1092-1 PN 10 through PN 400

Outlet Sizes: 2" through 16"

Outlet Ratings: ASME Class 150 and 300
EN 1092-1 PN 10 through PN 40

Orifice Sizes: D through W

Set Pressure Range: 4 to 6250 psig (0.27 to 431 barg)

Temperature Range: -450°F to 1500°F (-268°C to 815°C)

Materials: Cast carbon steel body with stainless steel trim

ASME B&PVC Section I (V Designator) (Liquid),
Section III & XIII (UV Designator)

PED

Certifications: China Manufacturing License (CML)

API 520, 521 and 526

NACE

Others available upon request

The highly adaptable 1900 Series Safety Relief Valve is designed to meet a wide range of industrial applications and is certified for gas, liquid and steam media in conventional and balanced bellows designs.

Options for 1900 Series Safety Relief Valve

1900-30

The 1900-30 Series valve includes the addition of a balanced bellows that is necessary to compensate for the effects of variable back pressure. By isolating the upper structure and allowing the use of less expensive materials, the bellows is also a cost-effective solution in applications where the valve is exposed to highly viscous or corrosive fluids.

1900-DA

The 1900-DA Series valve contains an additional O-ring seat seal. This soft seat is the primary seal and it allows the valve to remain leak free at 95 percent of set pressure over 100 psig (6.89 barg). A backup metal seat provides additional safety for fire-relief applications when O-rings can be destroyed by high temperature exposure.

The 1900-DA Series O-ring seat is available for set pressures up to 6250 psig (430.92 barg). Some soft seats offered by other manufacturers are limited to 1500 psig (103,42 barg).



19000 Series Safety Relief Valve

Inlet Sizes:	0.5" to 2"
Inlet Ratings:	Threaded and ASME Class 150 through 2500
Outlet Ratings:	Threaded and ASME Class 150 to 300
Orifice Sizes:	0.096 sq. in. through 0.567 sq. in.
Set Pressure Range:	5 to 8000 psig (0,34 to 551 barg)
Temperature Range:	-425°F to 1100°F (-254°C to 593°C)
Certifications:	ASME B&PVC Section III and XIII (UV)
	PED
	China Manufacturing License (CML)
	API 520 and 521
	NACE
	Others available upon request

The 19000 Series safety relief valve is ASME and PED certified. It meets and exceeds API seat tightness performance. The 19000 offers enhanced capacity and blowdown performance on many media types. In most cases, it does not require parts changes to accommodate different media.

Options for 19000 Series Safety Relief Valve

19000-MS Standard Design

Metal-to-metal seat construction. Seat tightness compliant with API 527.

19000-DA Series O-Ring Seat Option

Soft seat design offers bubble tight seats at up to 97 percent of valve set pressure for valves set at 101 psig (6.96 barg) and above. This option promotes higher, more efficient system operating pressures without significant seat leakage concerns.

Consolidated Safety Relief Valves



1982 Series Safety Relief Valve

Inlet Sizes: 0.5" through 2"

Inlet Ratings: Threaded

Outlet Ratings: Threaded

Orifice Sizes: Four sizes – .121 sq. in. through 1.399 sq. in.

Set Pressure Range: 10 to 500 psig (0,69 to 34,47 barg)

Temperature Range: -20°F to 800°F (-29°C to 427°C)

Materials: Carbon steel bonnet with stainless steel trim

Certifications: ASME B&PVC, Section III
ASME B&PVC, Section XIII (UV)

The 1982 Series safety relief valve is a preferred choice for OEM and skid manufacturers requiring high-relief capacity from a small valve. The 1982 offers superior seat tightness and blowdown performance for most media applications.

2478 Series Relief Valve

Inlet Sizes: 0.5" through 2.5"

Outlet Sizes: 0.75" through 2.5"

Inlet Rating: Threaded

Outlet Rating: Threaded

Orifice Sizes: D, E, F, G, H and J

Set Pressure Range: 15 to 300 psig (1 to 20,68 barg)

Temperature Range: -325°F to 406°F (-198°C to 208°C)

Materials: Cast bronze bonnet, brass base and trim and PTFE soft seats

Certifications: Non-Coded

The 2478 Series pressure relief valve features an enclosed design for non-corrosive, thermal relief and liquid service applications.

Consolidated Pilot-Operated Safety Relief Valves

Consolidated offers zero leakage and multi-media certified pilot valve solutions for optimizing even the most demanding overpressure applications.

2900/2900 TM Series Gen II



The 2900 Series utilizes a full-nozzle design that protects the valve body from severe service conditions. When coupled with our cryodisc technology, the 2900 offers the most economical pilot-operated solution for cryogenic applications

3900/3900 TM Series

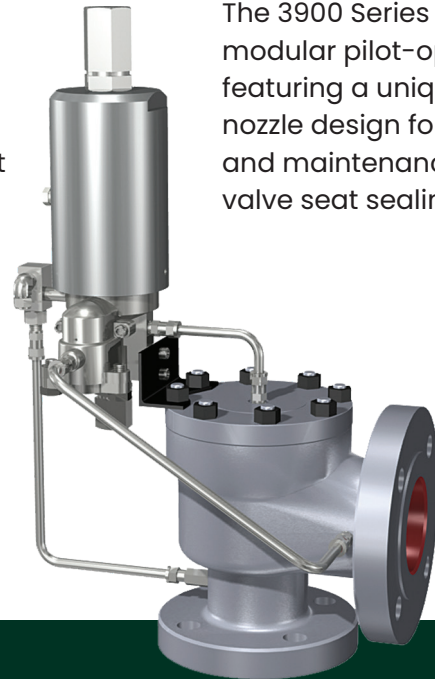

The 3900 Series is our modular pilot-operated SRV featuring a unique semi-nozzle design for easy access and maintenance of the main valve seat sealing area.

Triple Media (TM) Certified

The 2900 TM & 3900 TM Series POSRVs are engineered to perform on liquid, air/gas, and steam media and are multimedia certified per ASME B&PVC Code Case 2787 for nameplate capacities up to three medias; making the 2900/3900 TM the ideal solution for any liquid/gas/steam application, two-phase liquid and gas, flashing or multiple relief case scenarios.

Patented Integral Sensing Technology

Our patented 2900/2900 TM Series Gen II Integral Sense design offers a superior sensing option that doesn't require remote sense pipe tapping or piping modifications due to centerline to face dimensional differences. This unique solution enables safety relief valve (SRV) end users to replace existing oversized or misapplied API 526 Direct-Spring SRV's with our integrally sensed, full nozzle pilot-operated SRV's.

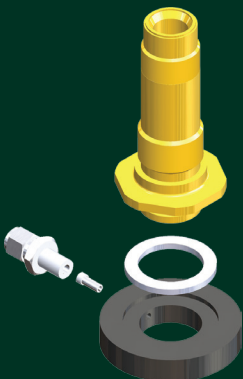

"True Zero Leakage Pilot"

The 'True Zero Leakage' modulating pilot provides a modernized overpressure protection solution for reducing carbon footprint, emissions, and product loss.



There is no need to shutdown with the Field Test Connection accessory that comes standard with every Consolidated pilot.

Consolidated Pilot-Operated Safety Relief Valves

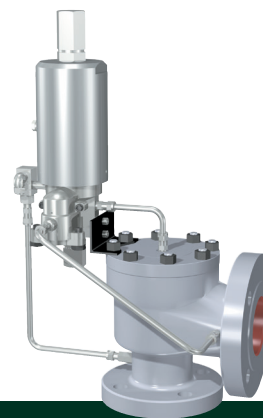

2900 Gen II Series Pilot-Operated Safety Relief Valve

Inlet Sizes: 1" through 12"

Inlet Ratings: ASME Class 150 through 2500
EN 1092-1 PN 10 through PN 400

Outlet Sizes: 2" through 16"

Outlet Ratings: ASME Class 150 and 300
EN 1092-1 PN 10 through PN 40

Orifice Sizes: Seventeen sizes – D through W

Set Pressure Range: 15 to 6250 psig
(1 to 431 barg)

Temperature Range: -40°F to 505°F (-40°C to 263°C)
Above 505°F with heat exchanger

Materials: Stainless steel pilot with carbon steel
main valve and stainless steel trim

ASME B&PVC Section I (V) (Liquid) & Section XIII
(UV) & Code Case 2787

Certifications: PED
China Manufacturing License (CML)

API 520, 521 and 526
(Same centerline-to-face as spring loaded valves)

NACE

Others available upon request

The 2900 Gen II Series pilot-operated safety relief valve combines the advantages of two products into one— the 1900 safety relief valve and the 3900 pilot. The 2900 POSRV with its patented integral sense design, can replace any API 526 spring-loaded relief valves without requiring modified outlet piping.

3900 Series Pilot-Operated Safety Relief Valve

Inlet Sizes: 1" through 12"

Inlet Ratings: ASME Class 150 through 2500

Outlet Sizes: 2" through 16"

Outlet Ratings: ASME Class 150 and 300

Orifice Sizes: Fourteen sizes – D through T (Full bores)

Set Pressure Range: Full Bores 15 to 6250 psig
(1 to 431 barg)

Temperature Range: -40°F to 505°F (-40°C to 263°C)
Above 505°F with heat exchanger

Materials: Stainless steel pilot with carbon steel
main valve and stainless steel trim

ASME B&PVC Section XIII (UV) &
Code Case 2787

Certifications: PED
China Manufacturing License (CML)

API 520, 521 and 526

NACE

Others available upon request

The 3900 Series pilot-operated safety relief valve is a non-flowing design available in a modulating or pop-action pilot. Consolidated POSRVs offer industry leading performance with both main valve and pilot seat tightness up to 98% of set pressure; ensuring zero-leakage during normal operating conditions for even the most demanding high-pressure applications.



4900 Series Pilot-Operated Safety Relief Valve

Inlet Sizes: 1" to 8"

Inlet Ratings: ASME Class 150 through 2500

Outlet Sizes: 2" through 10"

Outlet Ratings: ASME Class 150 and 300

Orifice Sizes: Fourteen sizes – D through T

Set Pressure Range: 15 to 7200 psig (1 to 496 barg)

Temperature Range: -40°F to 505°F (-40°C to 263°C)

Materials: Stainless steel pilot with carbon steel main valve and stainless steel trim

Certifications: ASME B&PVC Section XIII (UV)
PED

China Manufacturing License (CML)
API 520 and 521
NACE

Others available upon request

The 4900 Series pilot-operated safety relief valve is a tubeless valve for oil and gas production and the offshore industry.

13900 Series Pilot-Operated Safety Relief Valve

Inlet Sizes: 16" to 20"

Inlet Ratings: ASME Class 300

Outlet Sizes: 18" through 24"

Outlet Ratings: ASME Class 150

Orifice Sizes: 114, 143.1, 176.7 and 201 sq. in.

Set Pressure Range: 50 to 300 psig (3,44 to 20,68 barg)

Temperature Range: 250°F to 550°F (121°C to 288°C)

Materials: Carbon Steel with Stainless Steel trim

Typical Application: Moisture Separator Reheater Systems

Certifications: ASME B&PVC Section XIII (UV)
PED

China Manufacturing License (CML)
API 520 and 521

Others available upon request

The 13900 Series pilot-operated safety relief valve is configured for high-capacity steam overpressure protection for moisture separator reheater systems.

Consolidated Safety Valves

In compliance with:

- ASME Section I Code for Boiler Applications

Since 1879, Consolidated safety valves have been known for exceptional quality, performance and dependability. Because safety valves play an important role in keeping people and equipment safe, it is important that they be reliable in even the most demanding real-world applications. That's why Baker Hughes works closely with our customers and regulatory organizations to configure, engineer, and manufacture safety valves that can help maintain safer operating conditions in a full range of environments.

Key valve features

Our comprehensive portfolio of safety valves offer cost effective solutions for maintaining smooth steam operations safely. Consolidated safety valves feature a unique pop-action opening that can relieve over-pressurized steam quickly, when pressures upstream from the valve reach set point.

What is more, Consolidated safety valves comply with the ASME Section I code for boiler applications. They are built with many features that meet ASME requirements for steam-compressible fluids. For example, all models feature a lifting lever, required by the code for testing, instead of deadweight or weighted levers. Consolidated safety valves can also withstand set pressures up to 103 percent with a blowdown value of 4 percent, or 96 percent of set pressure drop before the valve re-seats.

A full range of valves

With a range of styles, models, options and configurations, Consolidated safety valves work in many different boiler applications.

Applications:

- Economizer (steam/water)
- Drum
- Superheater main steam line
- Supercritical
- Power actuated relief valve
- Cold re-heater line
- Hot re-heater line
- Soot blowers in forced flow steam generators
- Organic fluid vapor generators
- High temp hot water generators
- Electric boilers
- Waste heat recovery boilers





1700 Series Maxiflow™ Safety Valve

Inlet Sizes: 1.5" through 8"

Inlet Ratings: ASME Class 600 through 4500 Flanged and BWE

Outlet Sizes: 3" through 10" flanged

Outlet Ratings: ASME Class 150 and 300

Orifice Sizes: Eleven sizes – 1 through T

Set Pressure Range: 100 to 5800 psig (6.89 to 400 barg)

Temperature Range: Up to 1200°F (649°C)

Materials: Alloy and carbon steel cast body with stainless steel trim

Certifications: ASME B&PVC Section I (V) and Section XIII (UV)
PED
China Manufacturing License (CML)
Others available upon request

The 1700 Series Maxiflow high-pressure safety valve is a premium product that is installed on a majority of power generating stations worldwide to help protect boilers from overpressure conditions.

2700 Series Safety Valve

Inlet Sizes: 1.5" through 6"

Inlet Ratings: ASME Class 600, 900 and 1500

Outlet Sizes: 3" through 8"

Outlet Ratings: ASME Class 150 and 300

Orifice Sizes: Seven sizes – 1 through Q

Set Pressure Range: 100 to 2900 psig (6.89 to 200 barg)

Temperature Range: Up to 1050°F (565°C)

Materials: Alloy and carbon steel cast body with stainless steel trim

Certifications: ASME B&PVC Section I (V) and Section XIII (UV)
PED
China Manufacturing License (CML)
Others available upon request

The 2700 Series safety valve is configured to meet the specific requirements of the cogeneration and waste-to-energy markets.

Consolidated Safety Valves



1811 Series Safety Valve

Inlet Sizes: 1.25" through 6"

Inlet Ratings: ASME Class 150 through 600

Outlet Sizes: 1.5" through 8"

Outlet Ratings: ASME Class 150

Orifice Sizes: Ten sizes – F through Q

Set Pressure Range: 15 to 725 psig (1 to 50 barg)

Temperature Range: Up to 1000°F (538°C)

Materials: Alloy and carbon steel cast body with stainless steel trim

Certifications: ASME B&PVC Section I (V) and Section XIII (UV)
PED
China Manufacturing License (CML)
Others available upon request

The 1811 Series safety valve is a cost-effective, high-capacity, flanged-steel safety valve for steam service.

1511 Series Safety Valve

Inlet Sizes: 1.5" through 6"

Inlet Ratings: ASME Class 250

Outlet Sizes: 2.5" through 4"

Outlet Ratings: ASME Class 125

Orifice Sizes: Eight sizes – H through Q

Set Pressure Range: 15 to 250 psig (1 to 17,24 barg)

Temperature Range: -20°F to 420°F (-29°C to 215°C)

Materials: Cast iron body with brass trim

Certifications: ASME B&PVC Section I (V) and Section XIII (UV)
PED
China Manufacturing License (CML)
Others available upon request

The 1511 Series safety valve is configured for low pressure, steam heating boilers and steam generators as well as air service applications.



1541-3, 1543-3 Series Safety Valve

Inlet Sizes:	0.5" through 2.5"
Outlet Sizes:	0.75" through 2.5"
Inlet Rating:	Threaded
Outlet Rating:	Threaded
Orifice Sizes:	D, E, F, G, H and J
Set Pressure Range:	15 to 350 psig (1 to 24,13 barg)
Temperature Range:	-20°F to 420°F (-29°C to 215°C)
Materials:	Cast iron bonnet with brass base and trim
Certifications:	ASME B&PVC Section I (V) and Section XIII (UV)

The 1541 and 1543 Series safety valves are configured for steam and other compressible fluids. Compression media is limited to non-toxic, non-flammable, non-corrosive service. These valves are most commonly used in pharmaceutical and process plants.

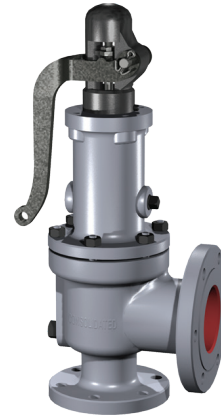

1900/P Series Safety Valve

Inlet Sizes:	1" through 8"
Inlet Ratings:	ASME Class 150 through 2500
Outlet Sizes:	2" through 10"
Outlet Ratings:	ASME Class 150 and 300
Orifice Sizes:	D through T
Set Pressure Range:	5 to 6000 psig (0,34 to 414 barg)
Temperature Range:	-20°F to 850°F (-29°C to 454°C)
Certifications:	ASME B&PVC, Section I (V) (Steam Service) API 520 and 527 Others available upon request

The 1900/P Series safety valve is designed to meet Economizer and Organic fluid applications.

Consolidated Pilot-Operated Safety Valves



2900-40 Series Pilot-Operated Safety Valve

Inlet Sizes: 1" through 12"

Inlet Ratings: ASME Class 150 through 2500
EN 1092-1 PN 10 through PN 400

Outlet Sizes: 2" through 16"

Outlet Ratings: ASME Class 150 and 300
EN 1092-1 PN 10 through PN 40

Orifice Sizes: D through W

Set Pressure Range: 15 to 5800 psig (1 to 400 barg)

Temperature Range: -40°F to 505°F (-40°C to 263°C)
Above 505°F with heat exchanger

Materials: Carbon steel base and 316 stainless steel
internal components; pilot valve 316 stainless steel

Certifications: ASME B&PVC Section I (V)
Certified for steam and water per ASME
B&PVC Code Case 2446
China Manufacturing License (CML)
API 520 and 521
Others available upon request

The 2900-40 Series pilot-operated safety valve offers exceptional performance and meets demanding ASME Section I Economizer and Boiler Applications.

Consolidated Electromatic Ball Valve System

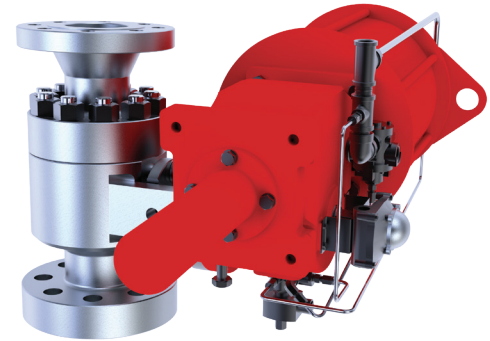

3500-5 Series EBV Electromatic™ Ball Valve System

Inlet Sizes: 1.5" / 2" / 2.5" / 3" / 4"

Inlet Ratings: ASME Class 1500, 2500, 3100 and 4500

Outlet Sizes: 3" / 4" / 6"

Outlet Ratings: ASME Class 300 and 900

Bore sizes: 0.875" / 1" / 1.75" / 2" / 2.5" / 3"
(Reduced bore sizes available without ASME V stamp.)

Set Pressure Range: 50 to 6000 psig
(3,45 to 414 barg)

Temperature Range: up to 1150°F (621°C)

Materials: Alloy steel body with Colmonoy® coated
inconel alloy ball and seat assembly

Certifications: ASME B & PVC Section I 'V' code stamp on
once through boilers (full bore only) and
non-code section I

The 3500-5 EBV Series offers automatic or manual overpressure protection for steam boiler systems, and can also be used to assist start-up and shut-down venting. The new enhanced design includes a superior coating and manufacturing process that enhances leak free performance, and improves reliability and increases valve life.



Providing Full-Service Support Locally Around the Globe

Baker Hughes's Aftermarket Centers (AMCs) are designed for advanced distribution systems for Consolidated products around the world. Together with our trained network of over 200 GTCs (Green Tag Centers), we can dispatch a qualified valve expert to nearly any location within hours.

Innovations to stock local modules and kits in region give the sites the ability to assemble and test a wide range of final valve configurations from our state-of-the-art **ValvFAST™** program. Local technicians and advance valve testing, including safety valve steam testing, allows our teams great flexibility to solve the urgent needs of our customers.

- Quality Aftermarket Products and Support
- Quick Access to OEM Parts, Kits and Complete Valves
- Advanced Machining, Testing and Technology to Quickly Fulfill Special Orders



Find the nearest local Channel Partner in your area:

valves.bakerhughes.com/contact-us

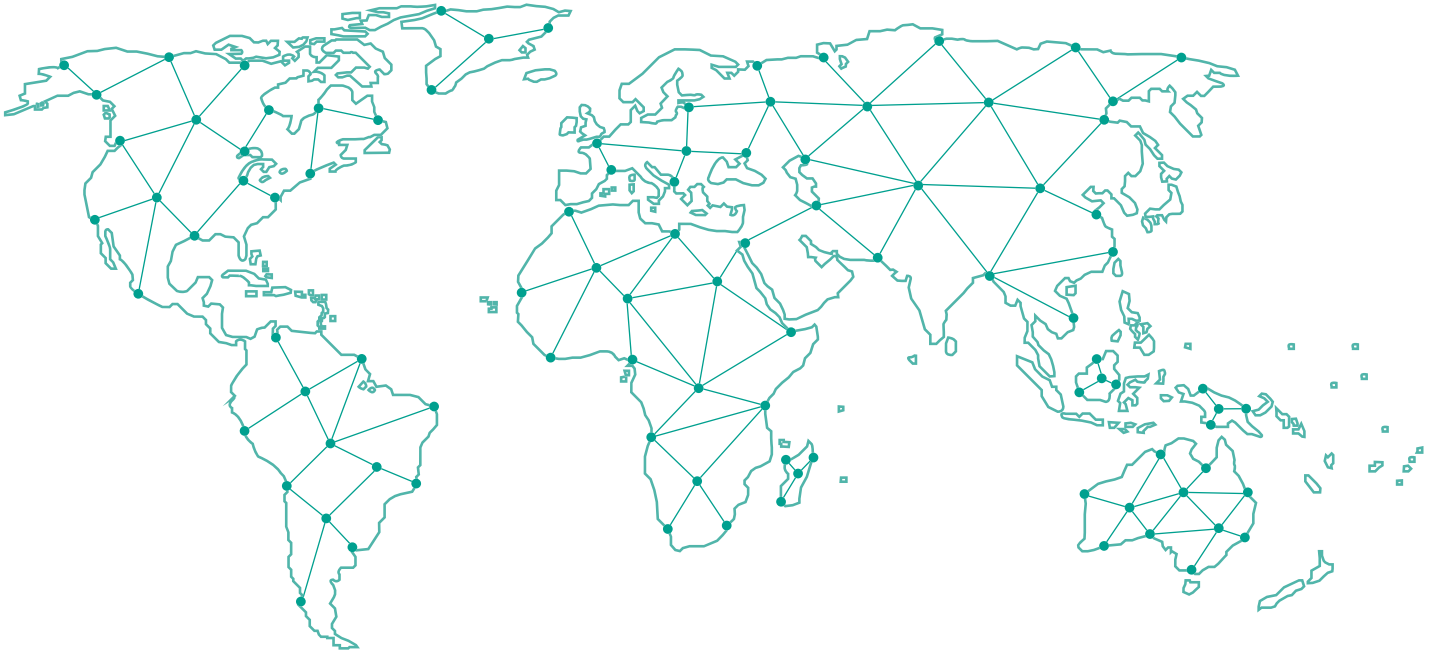

Tech Field Support and Warranty:

Phone: +1-866-827-5378
valvesupport@bakerhughes.com

valves.bakerhughes.com